

FIGURE 1 - SMALL PULPER ASSEMBLY

TABLE 1 - SMALL PULPER ASSEMBLY

FIG. & INDEX NO.	PART NUMBER	DESCRIPTION	QTY PER ASSY
1-1	NA	UPPER ASSEMBLY – TANK, FEED CHUTE, JUNK BOX, IMPELLER, AND SECURITY RING – SEE FIG. 2	1
1-2	NA	LOWER ASSEMBLY -MOTOR, BELT , DRIVE ASSEMBLY AND FRAME – SEE FIG. 3	1
1-3	NA	PIPING COMPONENTS – SEE FIG. 4	1
1-4	AJXXXXN6960500AY098	ELECTRICAL CONTROL ENCLOSURE – SEE FIG. 5	1

FIG. & INDEX NO.	PART NUMBER	DESCRIPTION	QTY PER ASSY
1-5	AJXXXXN6960502AY099	LOCAL STATUS INDICATOR	1

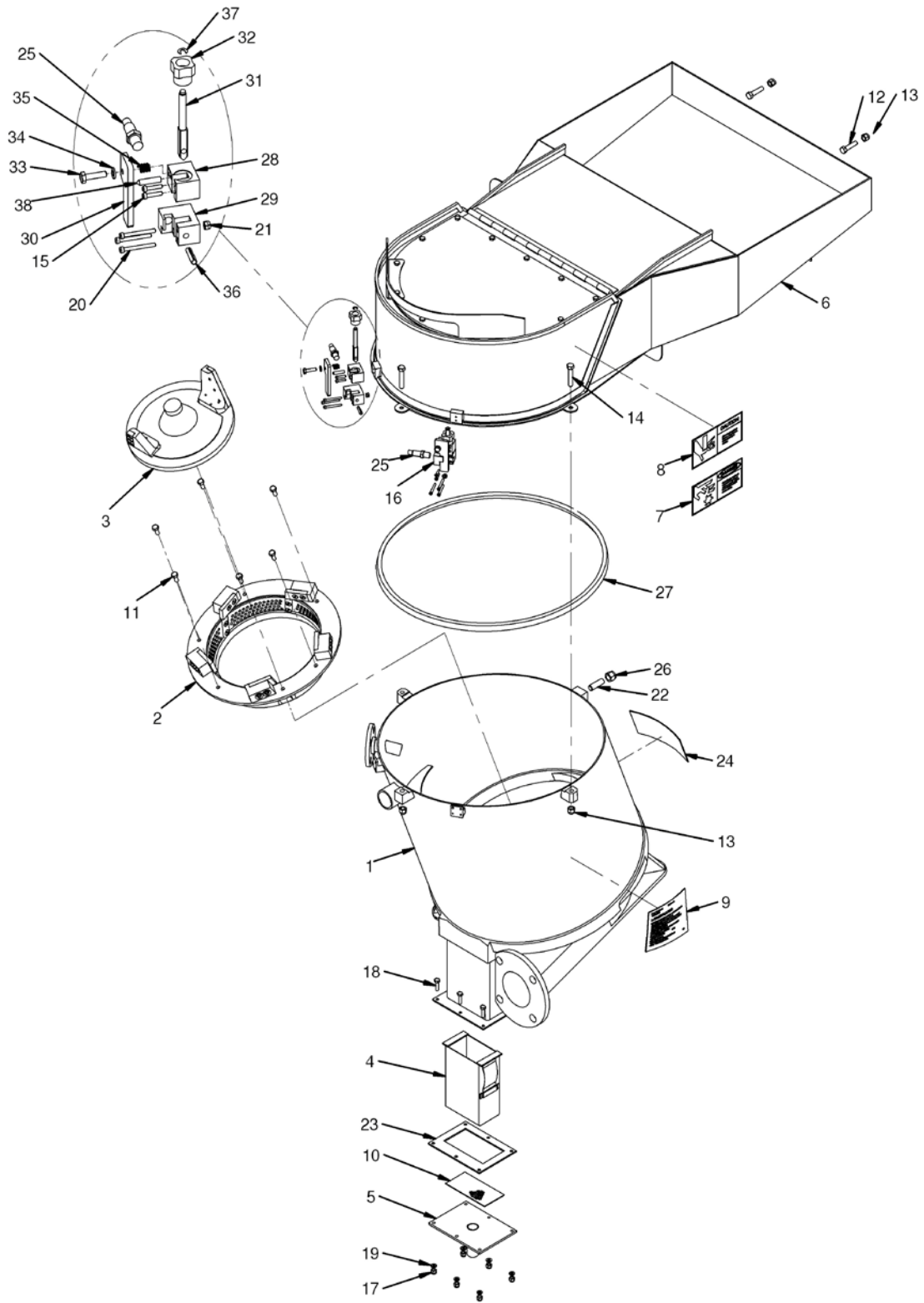

FIGURE 2 - UPPER ASSEMBLY

TABLE 2 - ASSEMBLY

FIG. & INDEX NO.	PART NUMBER	DESCRIPTION	QTY PER ASSY
2-1	AJXXXXN6960594AY099	TANK ASSEMBY	1
2-2	AJXXXXN6960604AY099	SECURITY RING ASSEMBLY	1
2-3	AJXXXXN6960598AY099	IMPELLER ASSEMBLY	1
2-4	AJXXXXN6960596AY099	JUNK BOX BASKET	1
2-5	AJXXXXN6960597AY099	JUNK BOX FLANGE	1
2-6	AJXXXXN6960585AY099	FEED CHUTE ASSEMBLY	1
2-7	AJXXXXN6960879PC002	IMPELLER HAZARD PLATE	1
2-8	AJXXXXN6960879PC004	FEED CHUTE & DOOR HAZARD PLATE	1
2-9	AJXXXXN6960879PC005	NAME PLATE	1
2-10	AJXXXXN6960581PC036	JUNK BOX SCREEN	1
2-11	AJXXXXN6960581PC045	CAP SCREW, HEX HEAD, .312-18UNC-2A X .75 LG, SST	6
2-12	AJXXXXN6960581PC046	CAP SCREW, HEX HEAD, .375-16UNC-2A X 1.25 LG, SST	6
2-13	AJXXXXN6960581PC047	ELASTIC LOCK NUT, .375-16UNC-2B, SST	11
2-14	AJXXXXN6960581PC049	CAP SCREW, HEX HEAD, .375-16UNC-2A X 2.00 LG, SST	3
2-15	AJXXXXN6960581PC050	CAP SCREW, HEX SOCKET HEAD, .164-32UNC-2A X .75 LG, SST	4
2-16	AJXXXXN6960614AY099	LID LATCH ASSEMBLY	2
2-17	AJXXXXN6960581PC054	ELASTIC LOCK NUT, .250-20UNC-2B, SST	6
2-18	AJXXXXN6960581PC055	CAP SCREW, HEX HEAD, .250-20UNC-2A X 1.00 LG, SST	6
2-19	AJXXXXN6960581PC056	FLAT WASHER, Ø.250 NOMINAL	6
2-20	AJXXXXN6960581PC060	CAP SCREW, HEX SOCKET HEAD, .164-32UNC-2A X 1.50 LG, SST	6
2-21	AJXXXXN6960581PC062	ELASTIC LOCK NUT, .164-32UNC-2B, SST	2
2-22	AJXXXXN6960581PC086	THREADED ROD, .500-13UNC-2A X 1.62 LG	1
2-23	AJXXXXN6960614PC020	JUNK BOX FLANGE GASKET	1
2-24	AJXXXXN6960879PC017	ROTATION LABEL	1
2-25	AJXXXXN6960611PC001	PROXIMITY SWITCH	2
2-26	AJXXXXN6960581PC058	ELASTIC LOCK NUT, .500-13UNC-2B, SST	6
2-27	AJXXXXN6960594PC015	TANK GASKET	1
2-28	AJXXXXN6960614PC011	UPPER LATCH BLOCK	2
2-29	AJXXXXN6960614PC012	LOWER LATCH BLOCK	2
2-30	AJXXXXN6960614PC013	SWITCH FLAG	2
2-31	AJXXXXN6960614PC014	SWING BOLT	2



FIG. & INDEX NO.	PART NUMBER	DESCRIPTION	QTY PER ASSY
2-32	AJXXXXN6960614PC015	KNOB, PHENOLIC PLASTIC WITH BRASS INSERT	2
2-33	AJXXXXN6960614PC016	CAP SCREW, HEX HEAD, .250-20UNC-2A X 1.00 LG, SST	2
2-34	AJXXXXN6960614PC017	FLAT WASHER, Ø.250 NOMINAL	2
2-35	AJXXXXN6960614PC018	COMPRESSION SPRING.36 O.D. X Ø.042 WIRE X .50 FREE LENGTH	2
2-36	AJXXXXN6960614PC019	SPRING PIN, SLOTTED, Ø.250 X 1.00 LG	2
2-37	AJXXXXN6960614PC021	RETAINING RING, EXTERNAL, Ø.250 NOMINAL	2

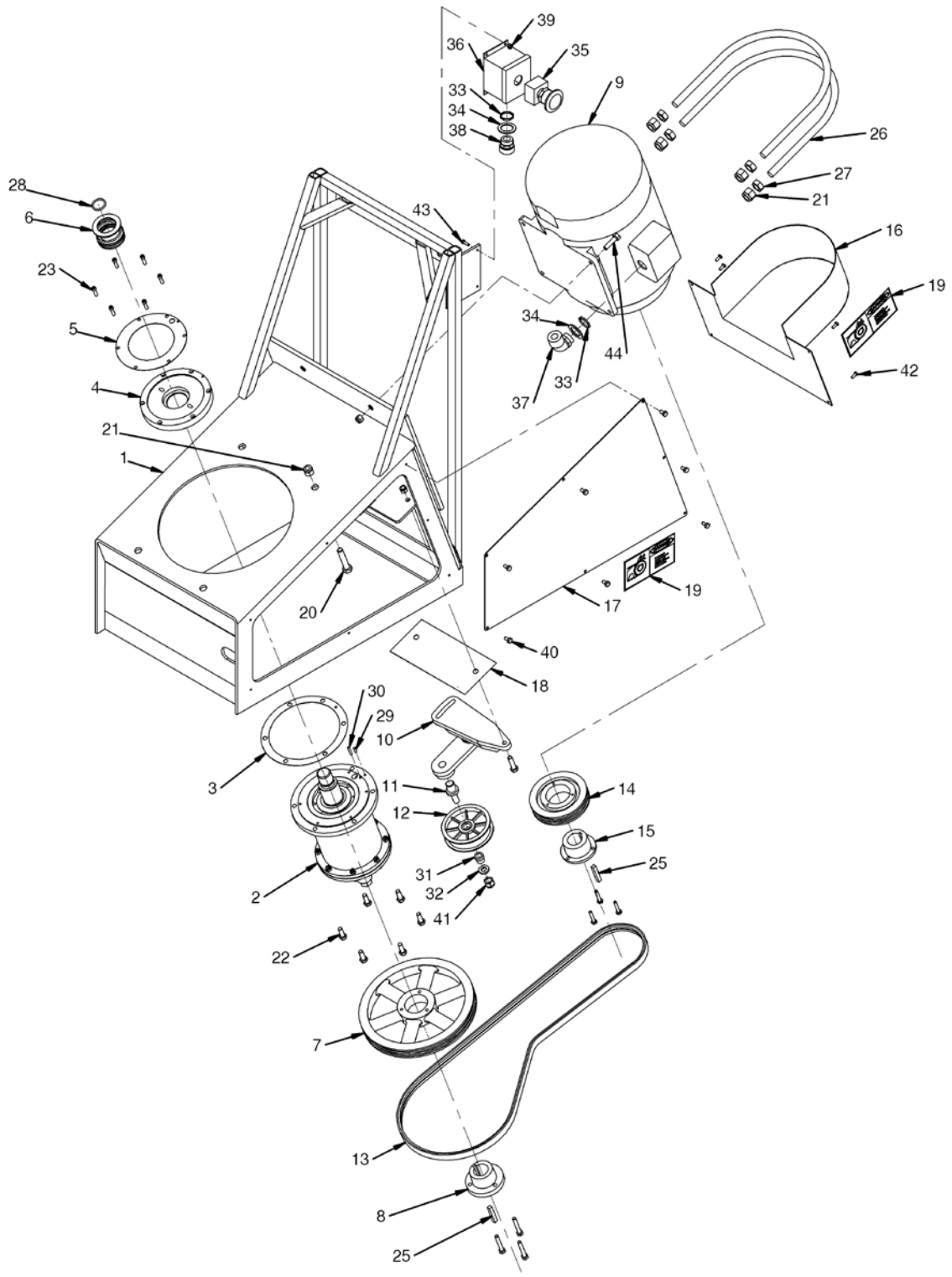

FIGURE 3 - LOWER ASSEMBLY

TABLE 3 - LOWER ASSEMBLY

FIG. & INDEX NO.	PART NUMBER	DESCRIPTION	QTY PER ASSY
3-1	AJXXXXN6960595AY099	FRAME ASSEMBLY	1
3-2	AJXXXXN6960586AY099	DRIVE ASSEMBLY	1
3-3	AJXXXXN6960590PC002	DRIVE HOUSING GASKET	1
3-4	AJXXXXN6960593PC001	DRIVE MECHANICAL SEAL PLATE	1
3-5	AJXXXXN6960590PC003	SEAL PLATE GASKET	1
3-6	AJXXXXN6960677AY099	DRIVE MECHANICAL SEAL	1
3-7	AJXXXXN6960581PC013	DRIVE SHEAVE	1
3-8	AJXXXXN6960581PC014	DRIVE HUB	1
3-9	AJXXXXN6960609PC001	DRIVE MOTOR	1
3-10	AJXXXXN6960619PC001	BELT TENSIONER	1
3-11	AJXXXXN6960624PC001	TENSIONER IDLER SHAFT	1
3-12	AJXXXXN6960625PC001	TENSIONER IDLER PULLEY	1
3-13	AJXXXXN6960581PC019	DRIVE BELT, DOUBLE-V, 3V PROFILE X 71.00 LG	1
3-14	AJXXXXN6960581PC020	MOTOR SHEAVE	1
3-15	AJXXXXN6960581PC021	MOTOR HUB	1
3-16	AJXXXXN6960621AY099	DRIVE GUARD	1
3-17	AJXXXXN6960621PC003	COVER	1
3-18	AJXXXXN6960614PC002	TENSIONER GASKET	1
3-19	AJXXXXN6960879PC003	DRIVE HAZARD PLATE	2
3-20	AJXXXXN6960581PC041	CAP SCREW, HEX HEAD, .625-11UNC-2A X 1.75 LG, SST	4
3-21	AJXXXXN6960581PC042	ELASTIC LOCK NUT, .625-11UNC-2B, SST	12
3-22	AJXXXXN6960581PC043	CAP SCREW, HEX HEAD, .375-16UNC-2A X 1.00 LG, SST	6
3-23	AJXXXXN6960581PC044	CAP SCREW, HEX SOCKET HEAD, .250-20UNC-2A X .88 LG, SST	6
3-24	AJXXXXN6960581PC048	CAP SCREW, HEX HEAD, .375-16UNC-2A X 1.50 LG, SST	2
3-25	AJXXXXN6960581PC070	KEY, SQUARE, .312 X 2.00 LG	2
3-26	AJXXXXN6960614PC001	MOTOR SHOCK SUPPORT	2
3-27	AJXXXXN6960581PC073	HEX NUT, .625-11UNC-2B, SST	4
3-28	AJXXXXN6960581PC084	O-RING, -215 SIZE (1.046 I.D. X .139 THK)	1
3-29	AJXXXXN6960581PC093	DOWEL PIN, Ø.188 X .50 LG	1
3-30	AJXXXXN6960581PC094	DOWEL PIN, Ø.188 X 1.00 LG	1
3-31	AJXXXXN6960581PC095	TENSIONER IDLER SHAFT ADAPTER	1
3-32	AJXXXXN6960581PC096	SPACER	1
3-33	AJXXXXN6960581PC101	LOCK NUT, ¾ NPT	2



FIG. & INDEX NO.	PART NUMBER	DESCRIPTION	QTY PER ASSY
3-34	AJXXXXN6960581PC102	SEALING WASHER WITH O-RING, ¾ NPT	2
3-35	AJXXXXN6960581PC107	PUSHBUTTON, EMERGENCY STOP	1
3-36	AJXXXXN6960581PC108	ENCLOSURE, SURFACE MOUNT	1
3-37	AJXXXXN6960581PC110	STUFFING TUBE WITH BUSHING, 90°, ¾ NPT, .62-.75 RANGE	1
3-38	AJXXXXN6960581PC118	STUFFING TUBE WITH BUSHING, ¾ NPT, STRAIGHT, .50-.62 RANGE	1
3-39	AJXXXXN6960581PC132	ELASTIC LOCK NUT, .190-24UNC-2B, SST	4
3-40	AJXXXXN6960581PC135	CAP SCREW, HEX HEAD, .250-20UNC-2A X .50 LG, SST	7
3-41	AJXXXXN6960581PC058	ELASTIC LOCK NUT, .500-13UNC-2B, SST	6
3-42	AJXXXXN6960581PC061	CAP SCREW, HEX HEAD, .190-24UNC-2A X .50 LG, SST	4
3-43	AJXXXXN6960581PC053	CAP SCREW, HEX HEAD, .190-24UNC-2A X .62 LG, SST	4

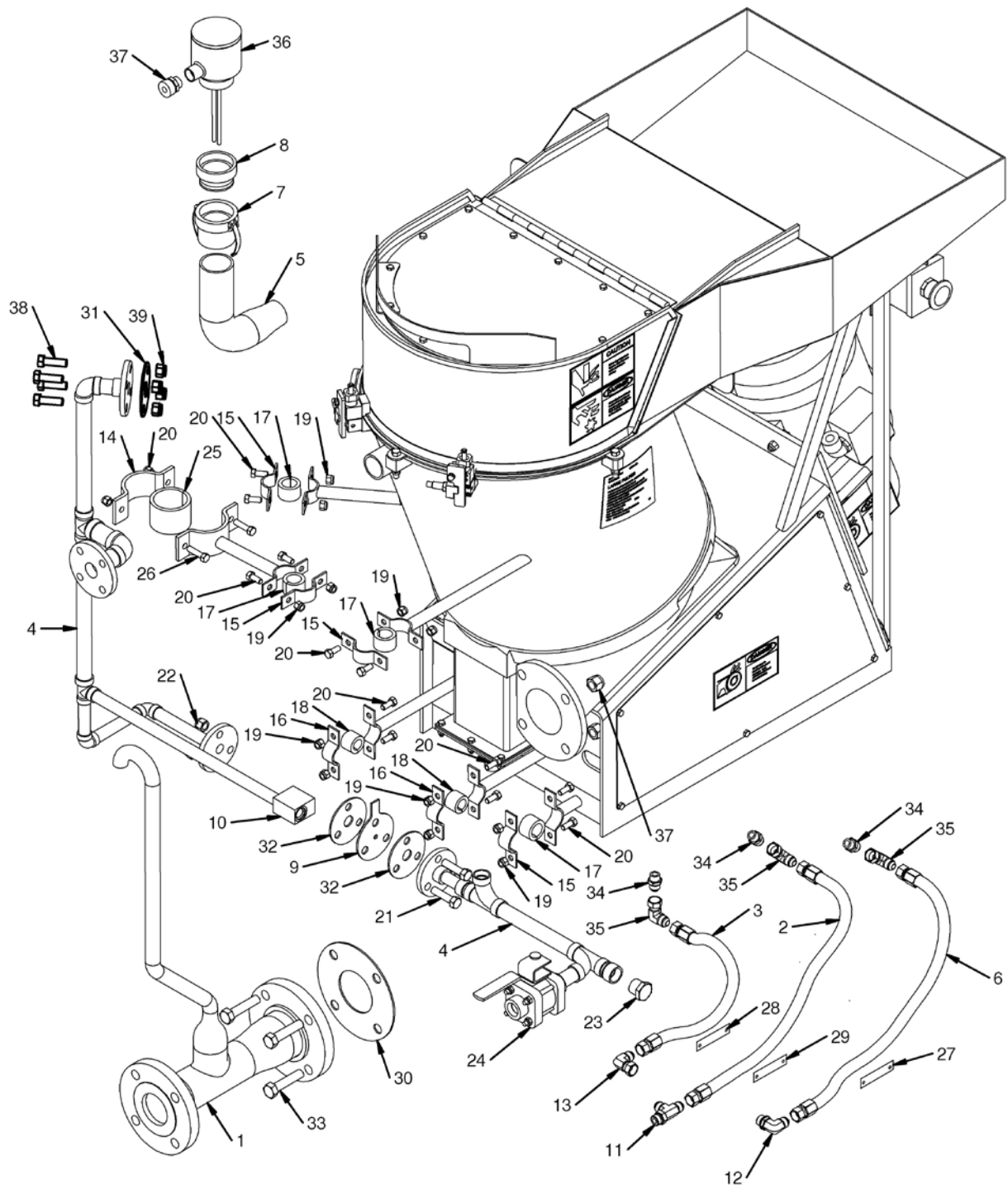

FIGURE 4 - PIPING COMPONENTS

TABLE 4 - PIPING COMPONENTS

FIG. & INDEX NO.	PART NUMBER	DESCRIPTION	QTY PER ASSY
4-1	AJXXXXN6960584AY098	OUTLET PIPING ASSEMBLY	1
4-2	AJXXXXN6960584AY095	LONG IMPELLER FLUSH HOSE ASSEMBLY	1
4-3	AJXXXXN6960584AY094	SHORT IMPELLER FLUSH HOSE ASSEMBLY	1
4-4	AJXXXXN6960584AY093	INLET PIPING ASSEMBLY	1
4-5	AJXXXXN6960584AY091	OVERFLOW PIPING ASSEMBLY	1
4-6	AJXXXXN6960584AY090	SEAL FLUSH HOSE ASSEMBLY	1
4-7	AJXXXXN6960584PC006	COUPLER, BOSS-LOCK, 2" FEMALE X 2 FEMALE NPT	1
4-8	AJXXXXN6960584PC007	ADAPTER, BOSS-LOCK, 2" MALE X 2 FEMALE NPT	1
4-9	AJXXXXN6960584PC015	ORIFICE PLATE	1
4-10	AJXXXXN6960584PC044	ADAPTER	1
4-11	AJXXXXN6960584PC045	TEE, Ø.50 TUBE, STRAIGHT THREAD O-RING X 37° MALE FLARE X 37° MALE FLARE, SST	1
4-12	AJXXXXN6960584PC046	ELBOW, Ø.50 TUBE, STRAIGHT THREAD O-RING X 37° MALE FLARE	1
4-13	AJXXXXN6960584PC047	ELBOW, Ø.50 TUBE, 37° MALE FLARE X 37° MALE FLARE	1
4-14	AJXXXXN6960584PC050	PIPE CLAMP, 2" NPS	2
4-15	AJXXXXN6960584PC051	PIPE CLAMP, ¾" NPS	8
4-16	AJXXXXN6960584PC052	PIPE CLAMP, ½" NPS	4
4-17	AJXXXXN6960584PC053	PIPE CLAMP CUSHION, ¾" PIPE SIZE	4
4-18	AJXXXXN6960584PC054	PIPE CLAMP CUSHION, ½" PIPE SIZE	2
4-19	AJXXXXN6960584PC055	ELASTIC LOCK NUT, .375-16UNC-2B, SST	14
4-20	AJXXXXN6960584PC056	CAP SCREW, HEX HEAD, .375-16UNC-2A X .88 LG, SST	12
4-21	AJXXXXN6960584PC057	CAP SCREW, HEX HEAD, .500-13UNC-2A X 2.00 LG, SST	3
4-22	AJXXXXN6960584PC058	ELASTIC LOCK NUT, .500-13UNC-2B, SST	3
4-23	AJXXXXN6960584PC073	PIPE PLUG, ¾ NPT	1
4-24	AJXXXXN6960584PC074	BALL VALVE, NAVY STANDARD, ¾" SIL-BRAZE X ¾-11.5-N.H. MALE HOSE THREADS	1
4-25	AJXXXXN6960584PC076	PIPE CLAMP CUSHION, 2" PIPE SIZE	1
4-26	AJXXXXN6960584PC077	CAP SCREW, HEX HEAD, .375-16UNC-2A X 1.25 LG, SST	2
4-27	AJXXXXN6960584PC078	MARKER PLATE, SEAL FLUSH HOSE	1



FIG. & INDEX NO.	PART NUMBER	DESCRIPTION	QTY PER ASSY
4-28	AJXXXXN6960584PC079	MARKER PLATE, SHORT IMPELLER FLUSH HOSE	1
4-29	AJXXXXN6960584PC080	MARKER PLATE, LONG IMPELLER FLUSH HOSE	1
4-30	AJXXXXN6960584PC084	GASKET, PIPE FLANGE, 3", ANSI 150 LB X .12 THK,	2
4-31	AJXXXXN6960584PC080	GASKET, PIPE FLANGE, 3/4", ANSI 150 LB X .12 THK,	1
4-32	AJXXXXN6960584PC080	GASKET, PIPE FLANGE, 1/2", NAVY TYPE 150 LB X .12 THK,	2
4-33	AJXXXXN6960581PC059	CAP SCREW, HEX HEAD, .625-11UNC-2A X 2.75 LG, SST	4
4-34	AJXXXXN6960581PC075	TUBE FITTING, .50 MALE 37° FLARE X .38 STRAIGHT THREAD O-RING	3
4-35	AJXXXXN6960581PC076	ELBOW, 90°, .50 MALE 37° FLARE X .50 FEMALE 37° FLARE SWIVEL	3
4-36	AJXXXXN6960633PC001	CONDUCTIVITY SWITCH	1
4-37	AJXXXXN6960581PC042	ELASTIC LOCK NUT, .625-11UNC-2B, SST	4
4-38	AJXXXXN6960581PC057	CAP SCREW, HEX HEAD, .500-13UNC-2A X 1.62 LG, SST	4
4-39	AJXXXXN6960581PC058	ELASTIC LOCK NUT, .500-13UNC-2B, SST	4



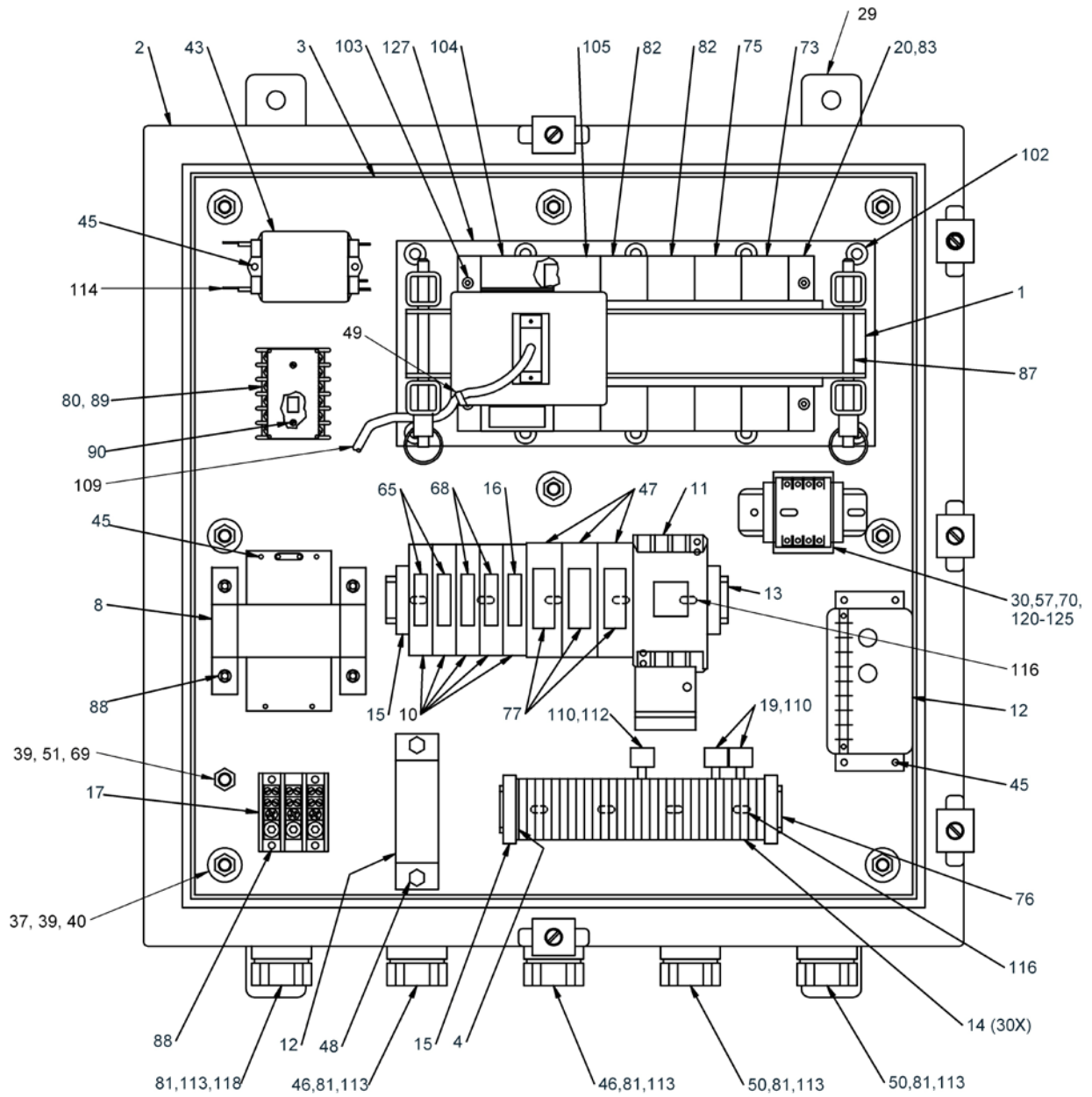

FIGURE 5 (SHEET 1) – ELECTRICAL CONTROL ENCLOSURE INTERIOR

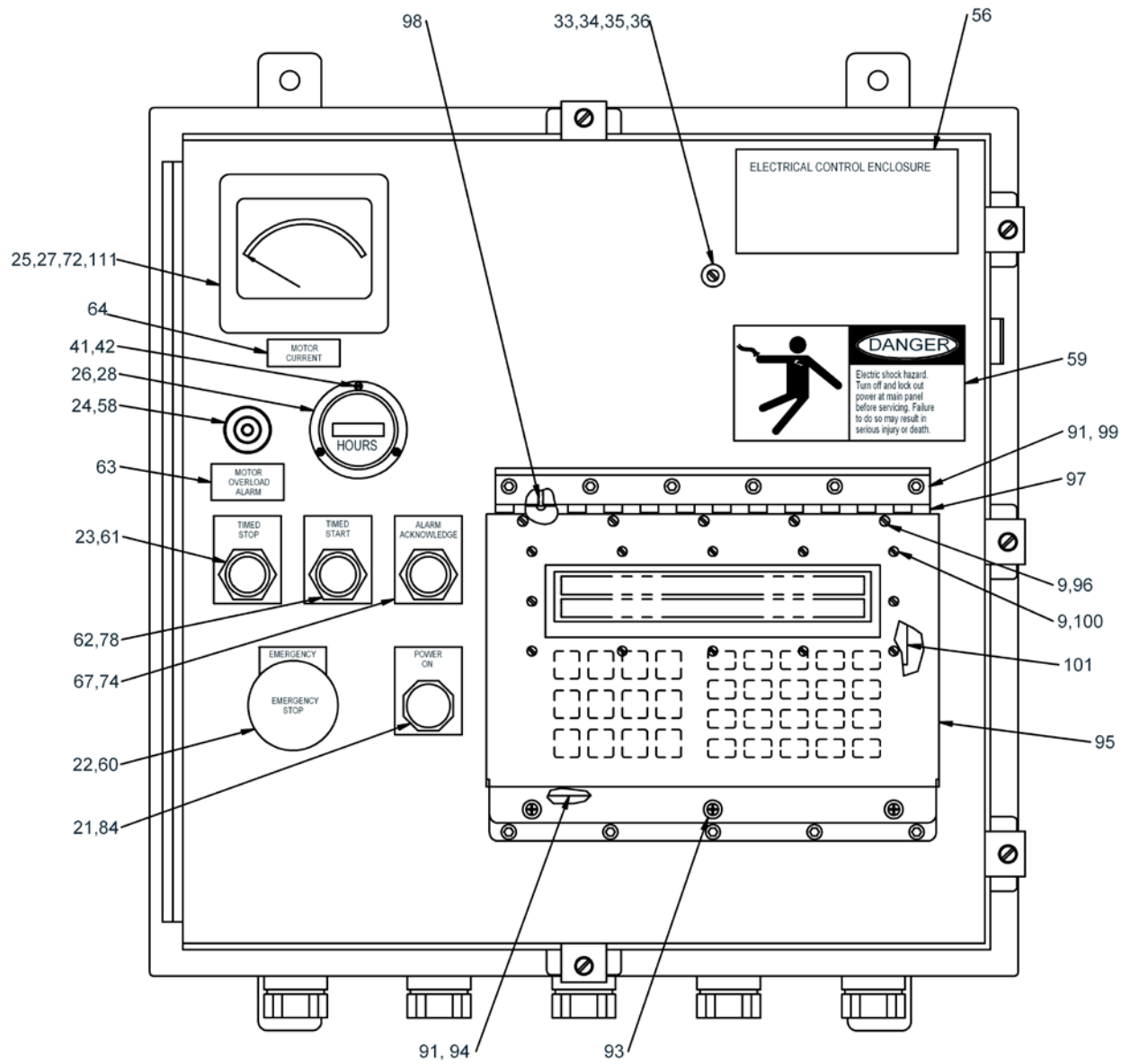

FIGURE 5 (SHEET 2) – FRONT OF ELECTRICAL CONTROL ENCLOSURE DOOR

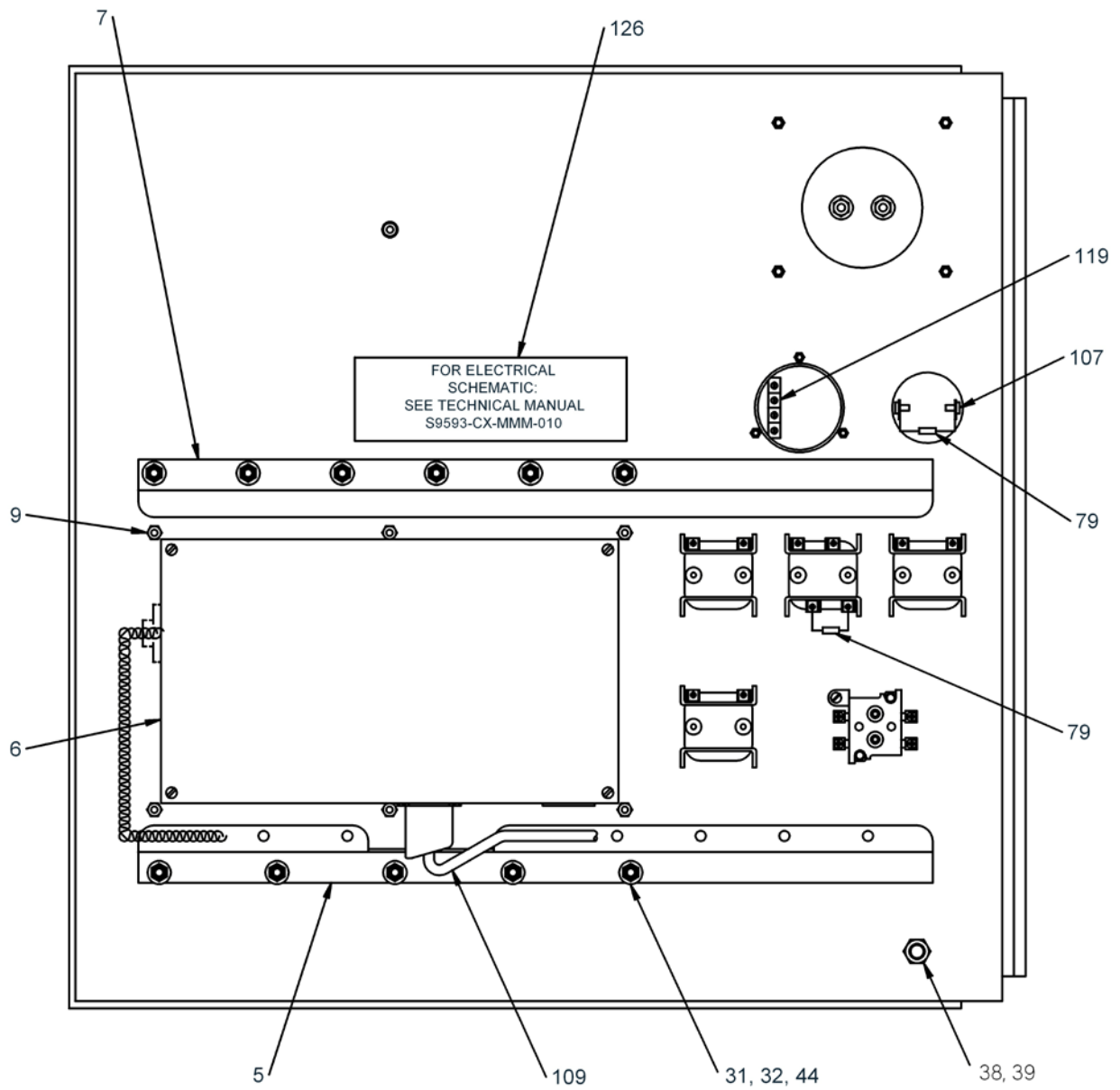

FIGURE 5 (SHEET 3) – REAR OF ELECTRICAL CONTROL ENCLOSURE DOOR

TABLE 5 – ELECTRICAL CONTROL ENCLOSURE

FIG. & INDEX NO.	PART NUMBER	DESCRIPTION	QTY PER ASSY
5-1	AJXXXXN6960500AY097	PLC HOLD-DOWN BRACKET	1
5-2	AJXXXXN6960500PC001	ENCLOSURE, 24" X 24" X 8"	1
5-3	AJXXXXN6960500PC002	PANEL, 21" X 21"	1
5-4	AJXXXXN6960500PC003	END BARRIER	1
5-5	AJXXXXN6960500PC004	DOOR STIFFENER, BOTTOM	1
5-6	AJXXXXN6960660PC001	MESSAGE DISPLAY UNIT	1
5-7	AJXXXXN6960500PC006	DOOR STIFFENER, TOP	1
5-8	AJXXXXN6960500PC007	TRANSFORMER, 440-110 VAC, 60 HZ, 300VA	1
5-9	AJXXXXN6960500PC008	ELASTIC LOCK NUT, .138-32UNC-2B	23
5-10	AJXXXXN6960500PC009	FUSE BLOCK, DIN RAIL	8
5-11	AJXXXXN6960500PC018	IEC NON-REVERSING STARTER, AC3 RATED FOR 10 A MIN	1
5-12	AJXXXXN6960500PC011	CURRENT TRANSDUCER, AND TRANSFORMER	1
5-13	AJXXXXN6960500PC012	SYMMETRICAL DIN RAIL, 10" LG	1
5-14	AJXXXXN6960500PC013	SINGLE CIRCUIT TERMINAL BLOCK, DIN RAIL MOUNT	30
5-15	AJXXXXN6960500PC015	END ANCHOR, DIN RAIL	4
5-16	AJXXXXN6960500PC016	FUSE, MIDGET, TIME DELAY, 250 V, 2 A	1
5-17	AJXXXXN6960500PC017	POWER DISTRIBUTION BLOCK, 3 POLE	1
5-18	AJXXXXN6960662PC001	PLC OUTPUT MODULE	1
5-19	AJXXXXN6960500PC020	CAPACITOR, SUPRESSOR, RADIAL, .1Uf, 250 VAC	2
5-20	AJXXXXN6960663PC001	PLC BASEPLATE	1
5-21	AJXXXXN6960500PC022	INDICATOR, WHITE, 110 VAC	1
5-22	AJXXXXN6960617PC001	PUSHBUTTON, E-STOP, JUMBO MUSHROOM HEAD, 2 N.C., RED, PUSH-PULL	1
5-23	AJXXXXN6960664PC001	PUSHBUTTON, 1 N.O.,EXTENDED HEAD, RED	1
5-24	AJXXXXN6960648PC001	ALARM, 4500 HZ, 120 VAC, 80 DB	1
5-25	AJXXXXN6960665PC001	AMMETER, 0-20 MA, ANALOG, SHADED SCALE	1
5-26	AJXXXXN6960651PC001	HOUR METER, 120 VAC, 60 HZ	1
5-27	AJXXXXN6960500PC028	AMMETER GASKET	1
5-28	AJXXXXN6960500PC029	HOUR METER GASKET	1
5-29	AJXXXXN6960500PC030	MOUNTING BAR	2
5-30	AJXXXXN6960500PC031	CABLE TIE, .14 W X 5.0 LG	AR



FIG. & INDEX NO.	PART NUMBER	DESCRIPTION	QTY PER ASSY
5-31	AJXXXXN6960500PC032	MACHINE SCREW, SOCKET FLAT HEAD .190-32UNF-2F X 1.00 LG	11
5-32	AJXXXXN6960500PC034	SEALING WASHER, .190 SCREW SIZE	11
5-33	AJXXXXN6960500PC035	BUMPER, Ø.62 X .62 LG, #8 HOLE SIZE	1
5-34	AJXXXXN6960500PC036	MACHINE SCREW, ROUND HEAD .164-32UNC-2F X .75 LG	1
5-35	AJXXXXN6960500PC038	ELASTIC LOCK NUT, .164-32UNC-2B	1
5-36	AJXXXXN6960500PC039	SEALING WASHER, .164 SCREW SIZE	1
5-37	AJXXXXN6960500PC040	CAP SCREW, HEX HEAD .375-16UNC-2A X 1.25 LG	8
5-38	AJXXXXN6960500PC041	CAP SCREW, HEX HEAD .375-16UNC-2A X .75 LG	1
5-39	AJXXXXN6960500PC042	ELASTIC LOCK NUT, .375-16UNC-2B	10
5-40	AJXXXXN6960500PC043	FLAT WASHER, Ø.375 NOMINAL	8
5-41	AJXXXXN6960500PC044	MACHINE SCREW, ROUND HEAD .112-40UNF-2A X .62 LG	3
5-42	AJXXXXN6960500PC045	ELASTIC LOCK NUT, .112-40UNC-2B	3
5-43	AJXXXXN6960666PC001	AC POWER LINE FILTER	1
5-44	AJXXXXN6960500PC047	ELASTIC LOCK NUT, .190-32UNF-2B	11
5-45	AJXXXXN6960500PC048	MACHINE SCREW, ROUND HEAD .164-32UNC-2A X .38 LG	10
5-46	AJXXXXN6960500PC049	STUFFING TUBE WITH BUSHING, .75 NPT, .62-.70 CABLE SIZE	2
5-47	AJXXXXN6960500PC051	CAP SCREW, HEX HEAD .250-20UNC-2A X .38 LG	2
5-48	AJXXXXN6960500PC052	CABLE TIE, .18 X 7.0 LG	AR
5-49	AJXXXXN6960500PC053	STUFFING TUBE WITH BUSHING, .75 NPT, .38-.50 CABLE SIZE	4
5-50	AJXXXXN6960500PC055	STUD, FULLY THREADED, .375-16UNC-2A X 2.00 LG	1
5-51	AJXXXXN6960500PC057	WIRE, HOOK UP, 14 AWG, 600 V, STRANDED, SILVER COATED, WHITE, 250 FT – NOT SHOWN	1
5-52	AJXXXXN6960500PC059	TERMINAL, RING TONGUE, 10 AWG, .38 STUD – NOT SHOWN	AR
5-53	AJXXXXN6960500PC060	TERMINAL, RING TONGUE, 22-18 AWG, .25 STUD – NOT SHOWN	2
5-54	AJXXXXN6960679PC016	LABEL PLATE, ELECTRICAL CONTROL ENCLOSURE, SMALL PULPER	1
5-55	AJXXXXN6960500PC063	WIRE, HOOK UP, 20 AWG, 600 V, STRANDED, SILVER COATED, RED, 50 FT LG	1
5-56	AJXXXXN6960500PC064	GASKET, MOTOR OVERLOAD ALARM	1



FIG. & INDEX NO.	PART NUMBER	DESCRIPTION	QTY PER ASSY
5-57	AJXXXXN6960879PC001	ELECTRICAL HAZARD PLATE	1
5-58	AJXXXXN6960500PC066	LABEL PLATE, EMERGENCY STOP (PB1)	1
5-59	AJXXXXN6960500PC067	LABEL PLATE, TIMED STOP	1
5-60	AJXXXXN6960500PC068	LABEL PLATE, TIMED START	1
5-61	AJXXXXN6960879PC009	LABEL PLATE, MOTOR OVERLOAD ALARM	1
5-62	AJXXXXN6960879PC011	LABEL PLATE, MOTOR CURRENT	1
5-63	AJXXXXN6960500PC071	FUSE, CLASS CC, 600 V, 2 A, TIMED DELAY	2
5-64	AJXXXXN6960500PC072	MARKER SLEEVE, HEAT SHRINKABLE, WHITE, .18 I.D. X 1.50 LG – NOT SHOWN	AR
5-65	AJXXXXN6960368PC001	PUSHBUTTON, 1 NO, FLUSH HEAD BLACK, MOMENTARY	1
5-66	AJXXXXN6960500PC075	FUSE, MIDGET, 250 V, 4 A, TIME DELAY	2
5-67	AJXXXXN6960500PC076	HEX NUT W EXTERNAL TOOTH LOCK WASHER, .375-16UNC-2B	1
5-68	AJXXXXN6960500PC077	CABLE TIE BASE, ADHESIVE BACK	AR
5-69	AJXXXXN6960500PC078	SPIRAL WRAP, NATURAL, .25 O.D. – NOT SHOWN	AR
5-70	AJXXXXN6960500PC081	HEX NUT, .138-32UNC-2B	8
5-71	AJXXXXN6960674PC001	PLC FILLER MODULE	1
5-72	AJXXXXN6960500PC083	LABEL PLATE, ALARM AKNOWLEDGE	1
5-73	AJXXXXN6960672PC001	PLC ANALOG OUTPUT MODULE	1
5-74	AJXXXXN6960500PC085	SYMMETRICAL DIN RAIL, 8.25 LG	1
5-75	AJXXXXN6960500PC094	FUSE, CLASS CD, 600 V, 20 A, TIME DELAY	3
5-76	AJXXXXN6960668PC001	PUSHBUTTON, 2 NO, MOMENTARY, FLUSH HEAD, GREEN	1
5-77	AJXXXXN6960500PC088	RESISTOR, 47 K OHM, ½ W, 10% TOLERANCE	2
5-78	AJXXXXN6960645PC001	RELAY, DPDT, 115 VAC, 10 A, 12 PIN	1
5-79	AJXXXXN6960500PC092	SEALING WASHER, .75 NPT	7
5-80	AJXXXXN6960667PC001	PLC INPUT MODULE	1
5-81	AJXXXXN6960500PC097	PLC PROM, INTEGRATED CIRCUIT, 28 PIN, PRE-PROGRAMMED	1
5-82	AJXXXXN6960500PC100	LABEL PLATE, POWER ON	1
5-83	AJXXXXN6960500PC102	TERMINAL, RING TONGUE, 16-14 AWG, #8 STUD – NOT SHOWN	AR
5-84	AJXXXXN6960500PC103	TERMINAL, RING TONGUE, 16-14 AWG, #6 STUD – NOT SHOWN	2



FIG. & INDEX NO.	PART NUMBER	DESCRIPTION	QTY PER ASSY
5-85	AJXXXXN6960500PC104	QUICK RELEASE PIN, PUSHBUTTON RELEASE, Ø.31 X 4.25 GRIP LENGTH	2
5-86	AJXXXXN6960500PC106	MACHINE SCREW, ROUND HEAD .190-32UNC-2A X .50 LG	8
5-87	AJXXXXN6960646PC001	RELAY SOCKET, 12 PIN, BOTTOM MOUNTED	1
5-88	AJXXXXN6960500PC111	MACHINE SCREW, ROUND HEAD .138-32UNC-2A X .75 LG	2
5-89	AJXXXXN6960500PC112	HOLD DOWN GASKET	1
5-90	AJXXXXN6960500PC113	GASKET	1
5-91	AJXXXXN6960500PC114	RETRACTABLE SCREW FASTENER, FLOATING WITH WASHER, .190-32UNF-2A	3
5-92	AJXXXXN6960500PC115	HOLD DOWN BAR	1
5-93	AJXXXXN6960500PC116	DISPLAY UNIT COVER	1
5-94	AJXXXXN6960500PC117	MACHINE SCREW, FLAT HEAD .138-32UNC-2A X .38 LG	5
5-95	AJXXXXN6960500PC118	HINGE, CONTINUOUS, 12.00 LG	1
5-96	AJXXXXN6960500PC119	MACHINE SCREW, ROUND HEAD .138-32UNC-2A X .38 LG	5
5-97	AJXXXXN6960500PC120	BAR	1
5-98	AJXXXXN6960500PC121	MACHINE SCREW, ROUND HEAD .138-32UNC-2A X .50 LG	12
5-99	AJXXXXN6960500PC122	LENS, DISPLAY UNIT, MAR-RESISTANT	1
5-100	AJXXXXN6960500PC123	CAP SCREW, FLAT HEAD .312-18UNC-2A X .62 LG	12
5-101	AJXXXXN6960500PC124	MACHINE SCREW, ROUND HEAD .190-32UNF-2A X .62 LG	4
5-102	AJXXXXN6960669PC001	PLC POWER SUPPLY	1
5-103	AJXXXXN6960670PC001	PLC ANALOG INPUT MODULE	1
5-104	AJXXXXN6960500PC127	TERMINAL, PUSH-ON, 16-14 AWG – NOT SHOWN	AR
5-105	AJXXXXN6960500PC128	TERMINAL, RING TONGUE, 22-18 AWG, #6 STUD	AR
5-106	AJXXXXN6960500PC129	TERMINAL, RING TONGUE, 22-18 AWG, #8 STUD – NOT SHOWN	AR
5-107	AJXXXXN6960673AY099	MESSAGE DISPLY CABLE ASSEMBLY	1
5-108	AJXXXXN6960500PC131	TUBING, HEAT SHRINK, BLACK, .046 I.D.	AR
5-109	AJXXXXN6960500PC132	ELASTIC LOCK NUT, .250-28UNF-2B	8
5-110	AJXXXXN6960500PC133	RESISTOR, 15 K OHM, 1 W, 10% TOLERANCE	1
5-111	AJXXXXN6960500PC135	LOCKING NUT, .75 NPT	7



FIG. & INDEX NO.	PART NUMBER	DESCRIPTION	QTY PER ASSY
5-112	AJXXXXN6960500PC136	ADAPTER, NON-INSULATED, 2 MALE DISCONNECTS TO 1 FEMALE DISCONNECT	2
5-113	AJXXXXN6960500PC138	TERMINAL, RING TONGUE, 16-14 AWG, .38 STUD – NOT SHOWN	AR
5-114	AJXXXXN6960500PC139	MACHINE SCREW, ROUND HEAD .190-32UNF-2A X .38 LG	9
5-115	AJXXXXN6960879PC006	CAUTION PLATE, IMPELLER ROTATION	1
5-116	AJXXXXN6960500PC142	STUFFING TUBE WITH BUSHING, .75 NPT, .50-.62 CABLE	1
5-117	AJXXXXN6960500PC143	TERMINAL, RING TONGUE, 16-14 AWG, #4 STUD	AR
5-118	AJXXXXN6960500PC144	CONDUCTIVITY SWITCH RELAY	1
5-119	AJXXXXN6960500PC145	SOCKET, DIN-RAIL, 8 PIN OCTAL	1
5-120	AJXXXXN6960500PC146	CLIP, RELAY	1
5-121	AJXXXXN6960500PC147	TERMINAL, FORK, 26-22 AWG	AR
5-122	AJXXXXN6960500PC148	END STOP	2
5-123	AJXXXXN6960500PC149	SYMMETRICAL DIN RAIL, 4.00 LG	1
5-124	AJXXXXN6960879PC075	LABEL, SCHEMATIC, SMALL PULPER	1
5-125	AJXXXXN6960500AY096	FRAME BRACKET ASSEMBLY	1

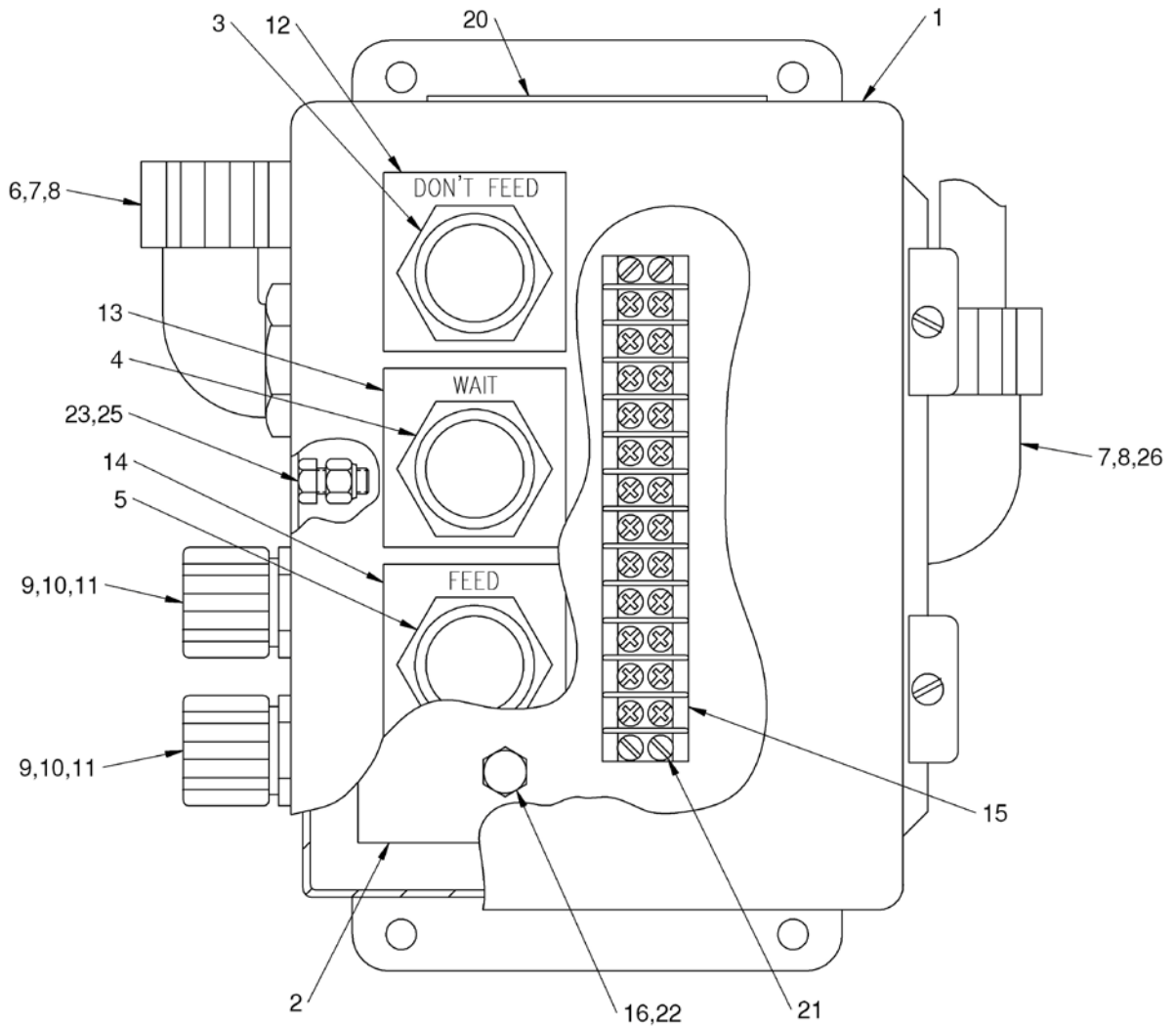

FIGURE 6 – LOCAL STATUS INDICATOR

TABLE 6 – LOCAL STATUS INDICATOR

FIG. & INDEX NO.	PART NUMBER	DESCRIPTION	QTY PER ASSY
6-1	AJXXXXN6960502PC001	ENCLOSURE, 8" H X 6" W X 4"	1
6-2	AJXXXXN6960502PC002	PANEL	1
6-3	AJXXXXN6960503PC003	INDICATOR, RED, "DON'T FEED"	1
6-4	AJXXXXN6960503PC004	INDICATOR, AMBER, "WAIT"	1
6-5	AJXXXXN6960503PC005	INDICATOR, GREEN, "FEED"	1

FIG. & INDEX NO.	PART NUMBER	DESCRIPTION	QTY PER ASSY
6-6	AJXXXXN6960503PC006	STUFFING TUBE WITH BUSHING, 90°, 3/4 NPT, .50-.62 CABLE RANGE	1
6-7	AJXXXXN6960503PC007	SEALING WASHER, 3/4 NPT	2
6-8	AJXXXXN6960503PC008	LOCKING NUT, 3/4 NPT	2
6-9	AJXXXXN6960503PC009	STUFFING TUBE WITH BUSHING, STRAIGHT, 1/2 NPT, .12-.19 CABLE RANGE	2
6-10	AJXXXXN6960503PC010	SEALING WASHER, 1/2 NPT	2
6-11	AJXXXXN6960503PC011	LOCKING NUT, 1/2 NPT	2
6-12	AJXXXXN6960503PC012	LABEL PLATE, FEED	1
6-13	AJXXXXN6960503PC013	LABEL PLATE, WAIT	1
6-14	AJXXXXN6960503PC014	LABEL PLATE, DON'T FEED	1
6-15	AJXXXXN6960503PC015	TERMINAL BLOCK, DOUBLE ROW, 15A, 12 POLE, 250V	1
6-16	AJXXXXN6960503PC016	THREADED INSERT, .250-20UNC-2B	1
6-17	AJXXXXN6960503PC018	TERMINAL, RING TONGUE, 16-14 AWG, #6 STUD	AR
6-18	AJXXXXN6960503PC019	MARKER SLEEVE, HEAT SHRINKABLE, .18 I.D. X 1.5 LG	AR
6-19	AJXXXXN6960503PC020	CABLE TIE, .14 WIDE X 5.0 LG – NOT SHOWN	AR
6-20	AJXXXXN6960879PC067	LABEL PLATE, LOCAL STATUS INDICATOR	1
6-21	AJXXXXN6960503PC023	MACHINE SCREW, ROUND HEAD .138-32UNC-2F X .50 LG	4
6-22	AJXXXXN6960503PC026	CAP SCREW, HEX HEAD .250-20UNC-2A X .50 LG	1
6-23	AJXXXXN6960503PC027	ELASTIC LOCK NUT, .250-20UNC-2B	1
6-24	AJXXXXN6960503PC029	TERMINAL, RING TONGUE, 16-14 AWG, .25 STUD	4
6-25	AJXXXXN6960503PC030	CAP SCREW, HEX HEAD .250-20UNC-2A X .38 LG	2
6-26	AJXXXXN6960503PC032	STUFFING TUBE WITH BUSHING, 90°, 3/4 NPT, .62-.75 CABLE RANGE	1
6-27	AJXXXXN6960503PC033	CABLE TIE BASE, ADHESIVE BACK – NOT SHOWN	AR



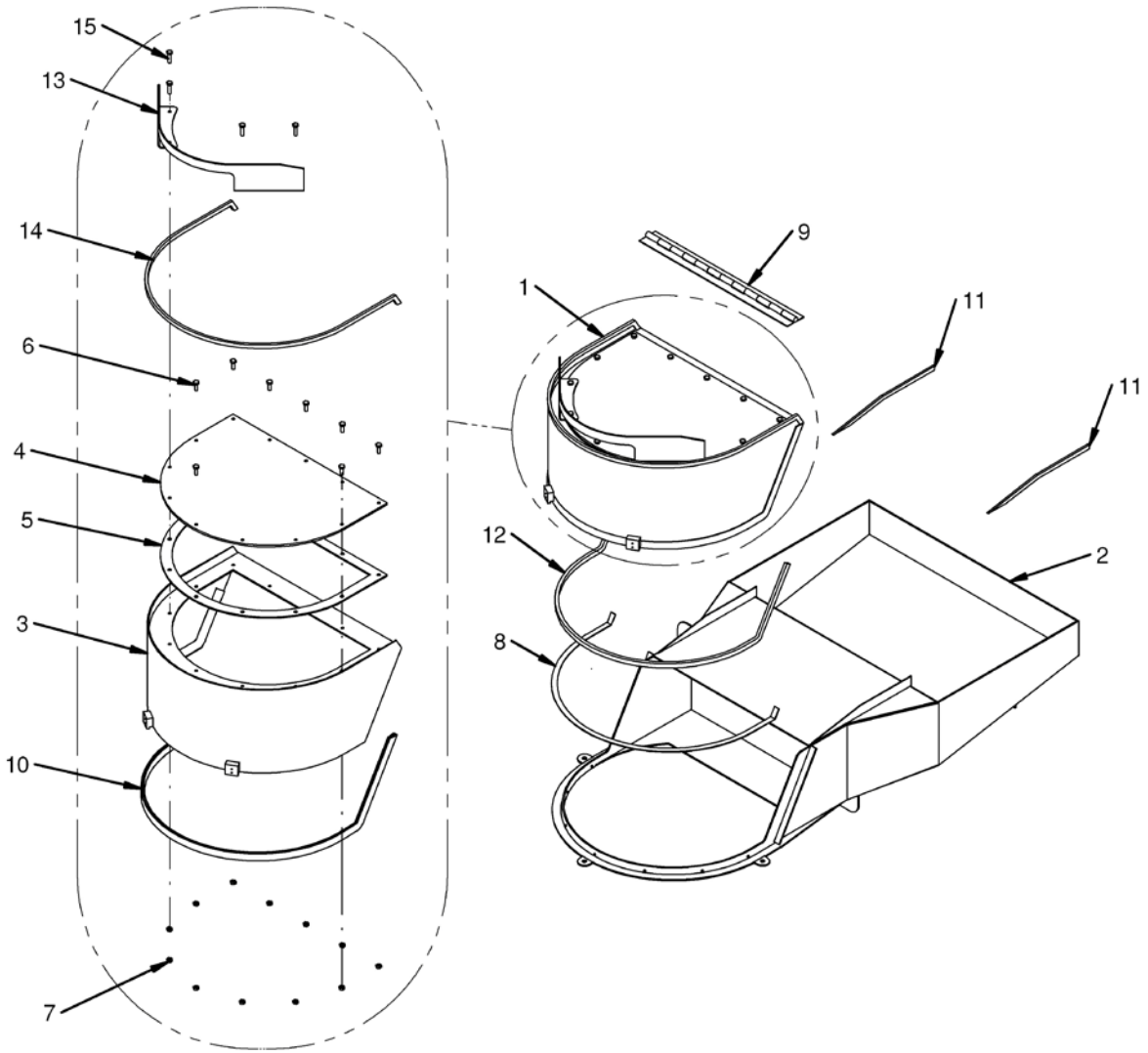

FIGURE 7 – FEED CHUTE ASSEMBLY

TABLE 7 – FEED CHUTE ASSEMBLY

FIG. & INDEX NO.	PART NUMBER	DESCRIPTION	QTY PER ASSY
7-1	AJXXXXN6960585AY098	FEED CHUTE COVER ASSEMBLY	1
7-2	AJXXXXN6960585AY097	FEED CHUTE WELDMENT	1
7-3	AJXXXXN6960585AY098	FEED CHUTE COVER WELDMENT	1
7-4	AJXXXXN6960585PC003	WINDOW	1
7-5	AJXXXXN6960585PC004	WINDOW GASKET	1
7-6	AJXXXXN6960585PC005	CAP SCREW, HEX HEAD, .250-20UNC-2A X .75 LG, SST	8
7-7	AJXXXXN6960585PC006	ELASTIC LOCK NUT, .250-20UNC-2B, SST	12
7-8	AJXXXXN6960585PC013	BLENDED SPONGE RUBBER, .50 WIDE X .06 THK, ADHESIVE BACK	AR
7-9	AJXXXXN6960585PC015	CONTINUOUS HINGE	1
7-10	AJXXXXN6960585PC019	OUTER SEAL	1
7-11	AJXXXXN6960585PC021	BUMPER	2
7-12	AJXXXXN6960585PC022	INNER SEAL	1
7-13	AJXXXXN6960585PC026	HANDLE	1
7-14	AJXXXXN6960585PC027	LIP BUMPER	1
7-15	AJXXXXN6960585PC028	CAP SCREW, HEX HEAD, .250-20UNC-2A X 1.00 LG, SST	4

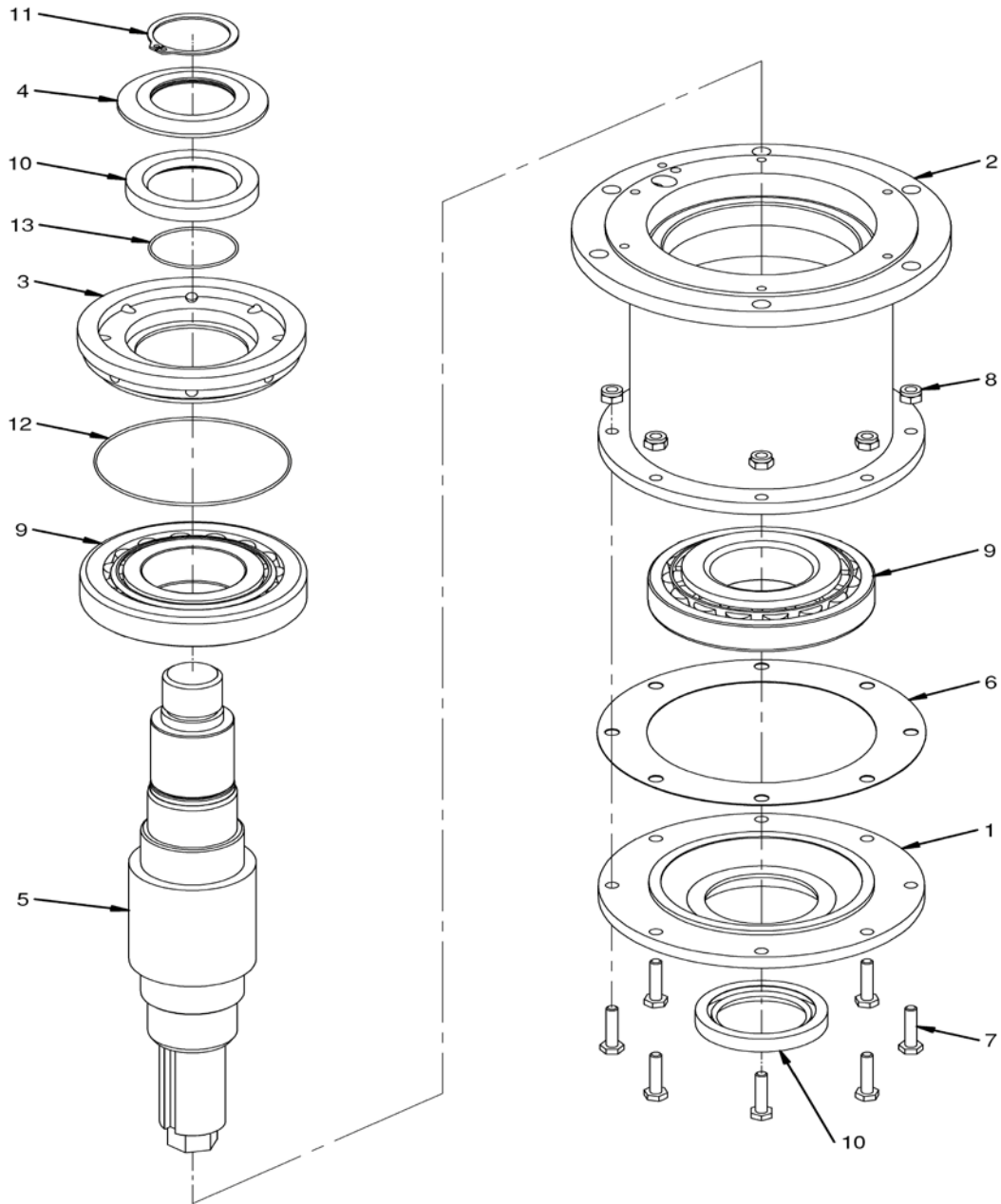

FIGURE 8 – IMPELLER DRIVE ASSEMBLY

TABLE 8 – IMPELLER DRIVE ASSEMBLY

FIG. & INDEX NO.	PART NUMBER	DESCRIPTION	QTY PER ASSY
8-1	AJXXXXN6960592PC001	DRIVE END CAP	1
8-2	AJXXXXN6960587PC001	DRIVE HOUSING	1
8-3	AJXXXXN6960589PC001	DRIVE LIP SEAL HOLDER	1
8-4	AJXXXXN6960589PC002	DRIVE FLINGER	1
8-5	AJXXXXN6960591PC001	DRIVE SHAFT	1
8-6	AJXXXXN6960586PC007	DRIVE SHIM	1
8-7	AJXXXXN6960586PC008	CAP SCREW, HEX HEAD, .250-20UNC-2A X 1.25 LG, SST	8
8-8	AJXXXXN6960586PC009	ELASTIC LOCK NUT, .250-20UNC-2B, SST	8
8-9	AJXXXXN6960586PC010	TAPERED BEARING ASSEMBLY, 55mm BORE X 120mm O.D. X 31.5mm THK	2
8-10	AJXXXXN6960586PC013	LIP SEAL, Ø1.88 SHAFT X 2.78 O.D. X .44 THK	2
8-11	AJXXXXN6960586PC015	RETAINING RING, EXTERNAL, Ø1.75 SHAFT	1
8-12	AJXXXXN6960586PC016	O-RING, -045 SIZE (4.013 I.D. X .070 THK)	1
8-13	AJXXXXN6960586PC017	O-RING, -031 SIZE (1.749 I.D. X .070 THK)	1

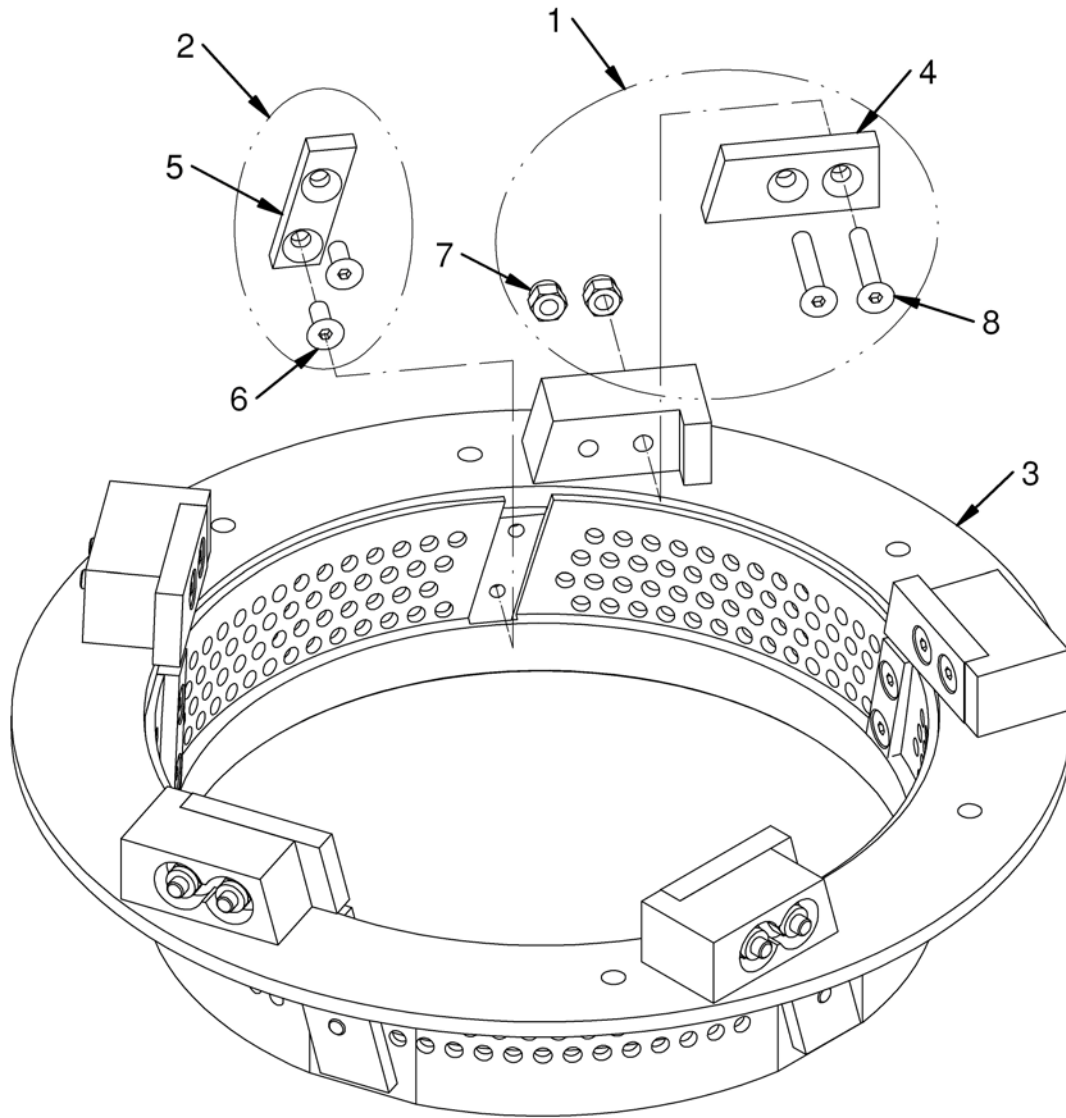

FIGURE 9 – SECURITY RING ASSEMBLY

TABLE 9 - SECURITY RING ASSEMBLY

FIG. & INDEX NO.	PART NUMBER	DESCRIPTION	QTY PER ASSY
9-1	AJXXXXN6960604AY098	SECURITY RING STATIONARY BLOCK BLADE KIT	1*
9-2	AJXXXXN6960604AY097	SECURITY RING LOWER BLADE KIT	1+
9-3	AJXXXXN6960605AY099	SECURITY RING WELDMENT	1
9-4	AJXXXXN6960606PC002	STATIONARY BLOCK BLADE	
9-5	AJXXXXN6960606PC003	LOWER BLADE	

FIG. & INDEX NO.	PART NUMBER	DESCRIPTION	QTY PER ASSY
9-6	AJXXXXN6960604PC006	CAP SCREW, SOCKET FLAT HEAD .250-28UNF-2A X .62 LG, SST	
9-7	AJXXXXN6960604PC007	ELASTIC LOCK NUT, .250-28UNF-2B, SST	
9-8	AJXXXXN6960604PC008	CAP SCREW, SOCKET FLAT HEAD .250-28UNF-2A X 1.50 LG, SST	

* INCLUDES 10 EACH ITEMS 9-7 AND 9-8, AND 5 EACH ITEM 9-4

+ INCLUDES 10 EACH ITEM 9-6, AND 5 EACH ITEM 9-5

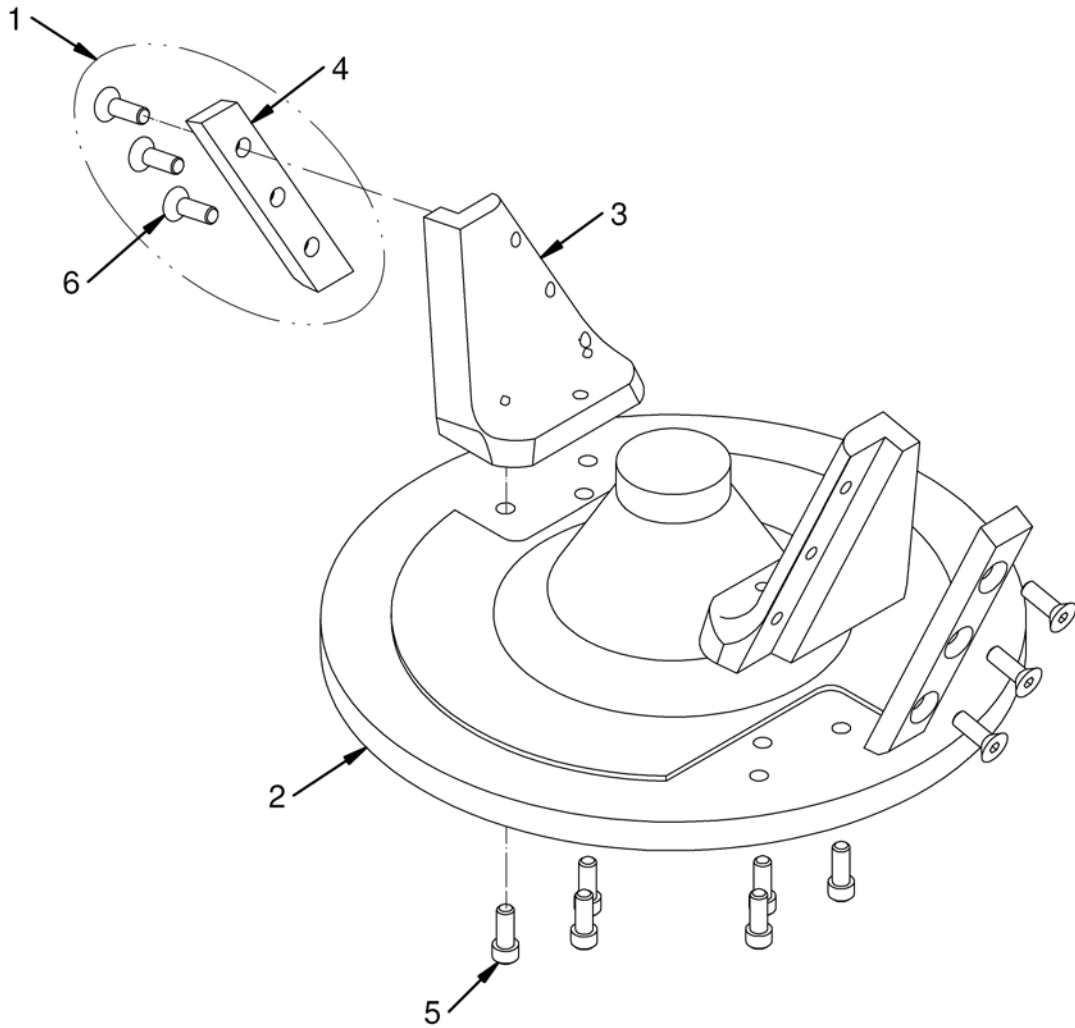

FIGURE 10 –IMPELLER ASSEMBLY

TABLE 10 - IMPELLER ASSEMBLY

FIG. & INDEX NO.	PART NUMBER	DESCRIPTION	QTY PER ASSY
10-1	AJXXXXN6960598AY098	IMPELLER BLADE KIT	1*
10-2	AJXXXXN6960599PC002	IMPELLER	1
10-3	AJXXXXN6960601PC002	CUTTING EAR	2
10-4	AJXXXXN6960603PC001	CUTTING EAR BLADE	2
10-5	AJXXXXN6960598PC004	CAP SCREW, HEX SOCKET HEAD .250-28UNF-2A X .62 LG, SST	6
10-6	AJXXXXN6960598PC005	CAP SCREW, HEX SOCKET FLAT HEAD .250-28UNF-2A X .75 LG, SST	

* INCLUDES 6 EACH ITEM 10-6, AND 2 EACH ITEM 10-3